

TR24/75



Transformer
Transformateur

Range: Transformers / **Gamme :** Transformateurs

INSTALLATION MANUAL
MANUEL D'INSTALLATION

TR24/75 Transformer

PRODUCT PRESENTATION

- **Recommended for additional modules in the CENTAUR range.**
- **Insulation according to EN 61558-2-6.**
- **Class : II.**
- **Primary: 230V ac 50/60 Hz.**
- **Secondary: 24V ac/40VA.**

- Resistance: 4KV between primary and secondary inputs, 2.5KV between wires and metal carcass.
- Coated transformer with fixing lugs.
- Cable connection for primary input, terminal connection for secondary input.

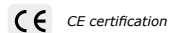
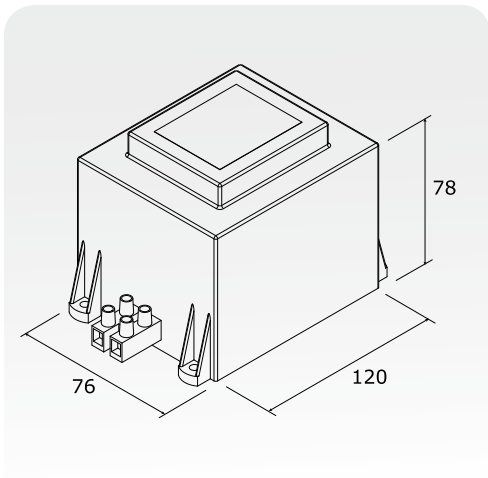

This product must be installed in accordance with the local safety standards.

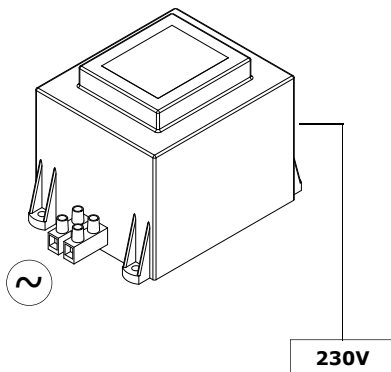



TR24/75

Transformateur

PRESENTATION DU PRODUIT

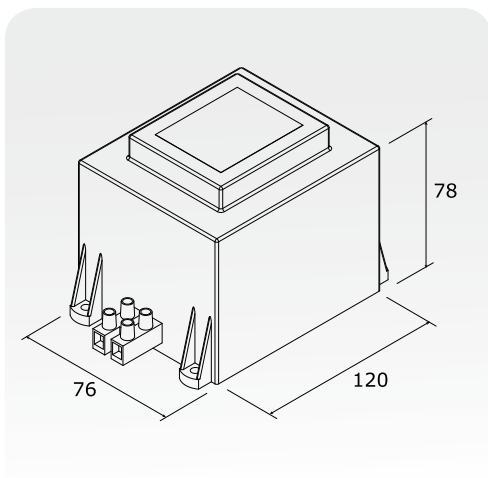
- **Préconisé pour les modules complémentaires de la gamme CENTAUR.**
 - **Isolation suivant EN 61558-2-6.**
 - **Classe : II.**
 - **Primaire : 230 V AC 50/60 Hz.**
 - **Secondaire : 24 V AC / 75 VA.**
- Tenue : 4 KV entre primaire / secondaire
 - 2.5 KV entre fils et carcasse métallique.
 - Transformateur enrobé avec oreilles de fixation.
 - Raccordement par câble pour le primaire, par bornes pour le secondaire.



 Certification DEEE & RoHS

 IP40

 Certification CE

Ce produit doit être installé selon les normes de sécurité électrique en vigueur dans votre pays

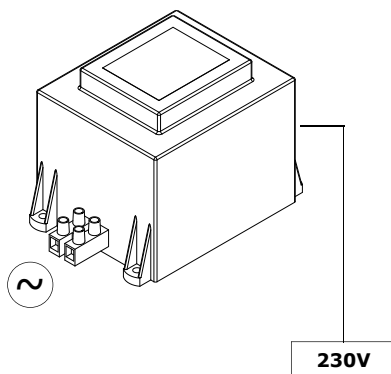

Manufacturing Access Control since 1985



All the specifications on this document (photos, drawing, features and dimensions) could be changed without prior notice.
Toutes les indications mentionnées sur le présent document (photos, dessins, caractéristiques et côtes) sont susceptibles de modifications sans notification préalable.

CDVI (Headquarters/Siège social)

FRANCE
Phone: +33 (0)1 48 91 01 02
Fax: +33 (0)1 48 91 21 21

CDVI

AMERICAS
Phone: +1 (450) 682 7945
Fax: +1 (450) 682 9590

CDVI

BENELUX
Phone: +32 (0)5 662 02 50
Fax: +32 (0)5 662 02 55

CDVI

SWITZERLAND
Phone: +41 (0)21 882 18 41
Fax: +41 (0)21 882 18 42

CDVI

CHINA
Phone: +86 (0)10 87664065
Fax: +86 (0)10 87664165

CDVI

IBÉRICA
Phone: +34 935 390 966
Fax: +34 935 390 970

CDVI

ITALIA
Phone: +39 0331 97 38 08
Fax: +39 0331 97 39 70

CDVI

MAROC
Phone: +212 5 22 48 09 40
Fax: +212 5 22 48 34 69

CDVI

SWEDEN
Phone: +46 (0)31 760 19 30
Fax: +46 (0)31 748 09 30

CDVI

UK
Phone: +44 (0)1628 531300
Fax: +44 (0)1628 531003

DIGIT

FRANCE
Phone: +33 (0)1 41 71 06 85
Fax: +33 (0)1 41 71 06 86

LA GÂCHE ÉLECTRIQUE

FRANCE
Phone: +33 (0)3 88 77 32 82
Fax: +33 (0)3 88 77 85 02