

# VingCard Signature RFID Electronic Lock

With Signature RFID you are provided with a stylish and modern lock that appeals to the modern hotel environment. Signature RFID is less on the door while more in terms of functionality for you and your guests.



## FEATURES

- : Supports the latest RFID technology
- : Supports Mobile Access
- : Online compatible
- : Easy upgrade from Signature Magstripe or Combo
- : Fire listed for use on fire doors (UL, BS, EN)
- : Case hardened full 1-inch (ANSI) throw deadbolt
- : Panic release function – the deadbolt and latch are automatically retracted by inside handle for easy regress in emergency situations
- : Stainless steel parts for mechanical strength, corrosion resistance and attractive appearance
- : Optional high security mechanical override cylinder

## DIMENSIONS

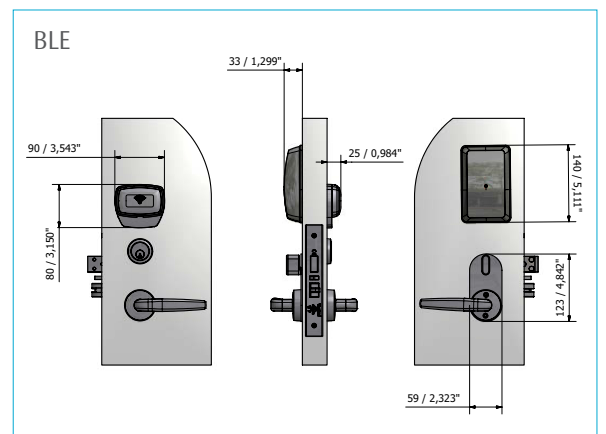
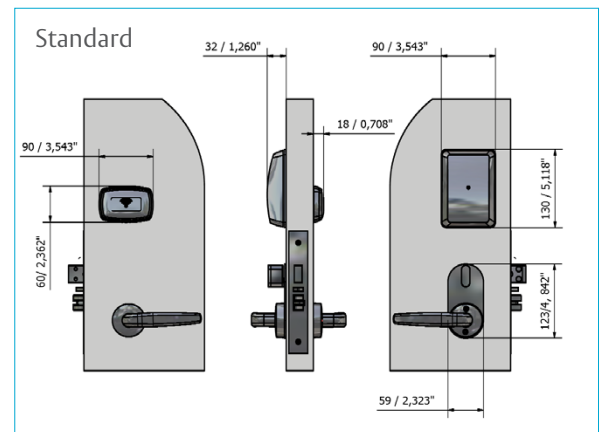

**ASSA ABLOY**

ASSA ABLOY Hospitality

The global leader in  
door opening solutions

## TECHNICAL DATA

Power	4,5 V DC (3 x AA alkaline batteries).
Battery location	Inside of the room.
Material	Thumbturn escutcheon: Stainless steel, quality SS316. Handles: Stainless steel quality SUS304. Battery cover: Polycarbonate (Makrolon 6265-vo / Lexan 945).RFID cover: Polycarbonate UL94V0 (Makrolon 6555)
Metal finishes	Satin Chrome (PVD), Polished Chrome (PVD), Satin Brass (PVD), Polished Brass (PVD), Light Bronze, Velour Nickel and US Antique Dark.
Standard plastic color	Black RAL 9005 (RFID cover and battery cover).
Handle options in standard range	Wing, Straight, Functional ANSI, Gothic.
Emergency opening options	Electronic emergency opening with service unit and optional mechanical cylinder.
User interface	3 colored LED display (green, red, yellow).
Locking mechanism	Electro-mechanical locking mechanism located in the lockcase.
Door thickness	34 - 120 mm / 1,34 - 4,72 Inches (thinner doors may be installed with a spacer).
System Software compatibility	Visionline and Vision.
Online compatibility	Wireless (based on ZigBee protocol) in Visionline Wired (PoE/Ethernet) in Visionline.
Storage temperature	0-70 °C / 32-158 °F: non-condensing environment.
Tested operating temperature	Tested from -25 °C to 70 °C ( -13 °F to 158 °F), according to IEC 60068-2.
Certifications	European EMC, LVD and R&TTE Directives Fire approved according to EN 1642-1, for use in fire doors with classification EI30 and EI60. Fire approved according to UL for 20 minutes (UL approved timber doors) and 3 hours (UL approved metal doors). Fire approved according to German MPA standard.

## LOCKCASE DIMENSIONS

ANSI lock case variants	ANSI DA, ANSI DB (both available in the following versions:4-switch, Auto deadbolt (ADB) Australia version (AUS) and Japan (JPN) version).
ANSI lock case widths	25 mm / 0,98 inches, 28 mm / 1,10 inches, 32 mm / 1,26 inches.
ANSI backset	70 mm / 2,76 inches.
EURO lock case variants	EURO, EURO ADB, EURO MPA.
EURO lock case widths	20 mm / 0,79 inches, 22 mm / 0,87 inches, 24 mm / 0,94 inches.
EURO backsets	65 mm / 2,56 inches, 80 mm / 3,15 inches.

